

FORMA DE SUMINISTRO

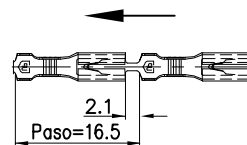

E 1:1

Secc. Y-Y'

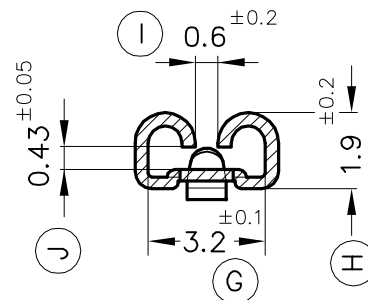

Secc. Z-Z'

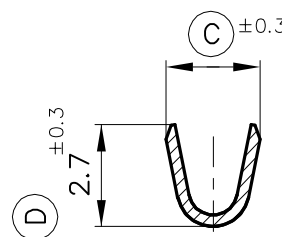

Secc. X-X'

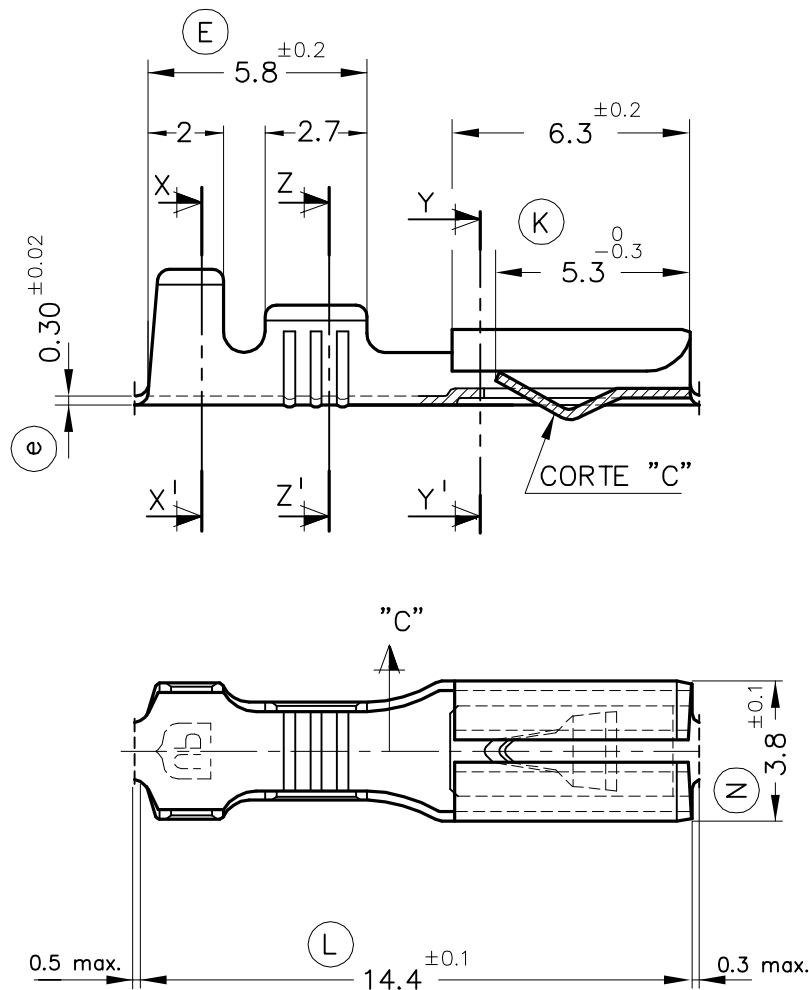
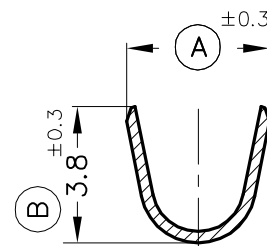

4508.24	Pre-Niq.	Acero				3.5	2.6	02	Geo. Retención	26/09/11	
4508.02	Estañado	Latón*	0.5 ± 1mm. <sup>2</sup>	1.8 ± 2.5mm.	2.8x0.5	3.8	2.8	01	Cot.C Laton(2.6a2.8)	28/11/00	
4508.00	Natural	CuZn30						00	1ª Edición	29/04/96	
Referencias	Acabados	Material	Sección Conductor	∅ Aislante	Para Macho	A	B	C	Rev.	Modificación	Fecha

<p>ESPECIALITATS ELÈCTRIQUES ESCUBEDO S.A.</p>			<h2>TERMINAL HEMBRA 2.8</h2>				Terminales	
DIBUJADO	Gemma	29/04/96	NORMAS MATERIALES EN1654*	NORMAS DIMENSIONALES Especiales	TOLERANCIAS GENERALES ±0.2 ±2°	FORMATO	A4v	
CONTROL	F.Adamuz	29/04/96				NOMBRE	PT4508 "c"	
ESCALA	5/1					REF.	4508.xx	