

FORMA DE SUMINISTRO

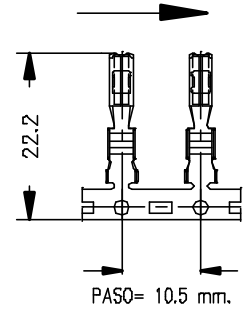

Esc. 1:1

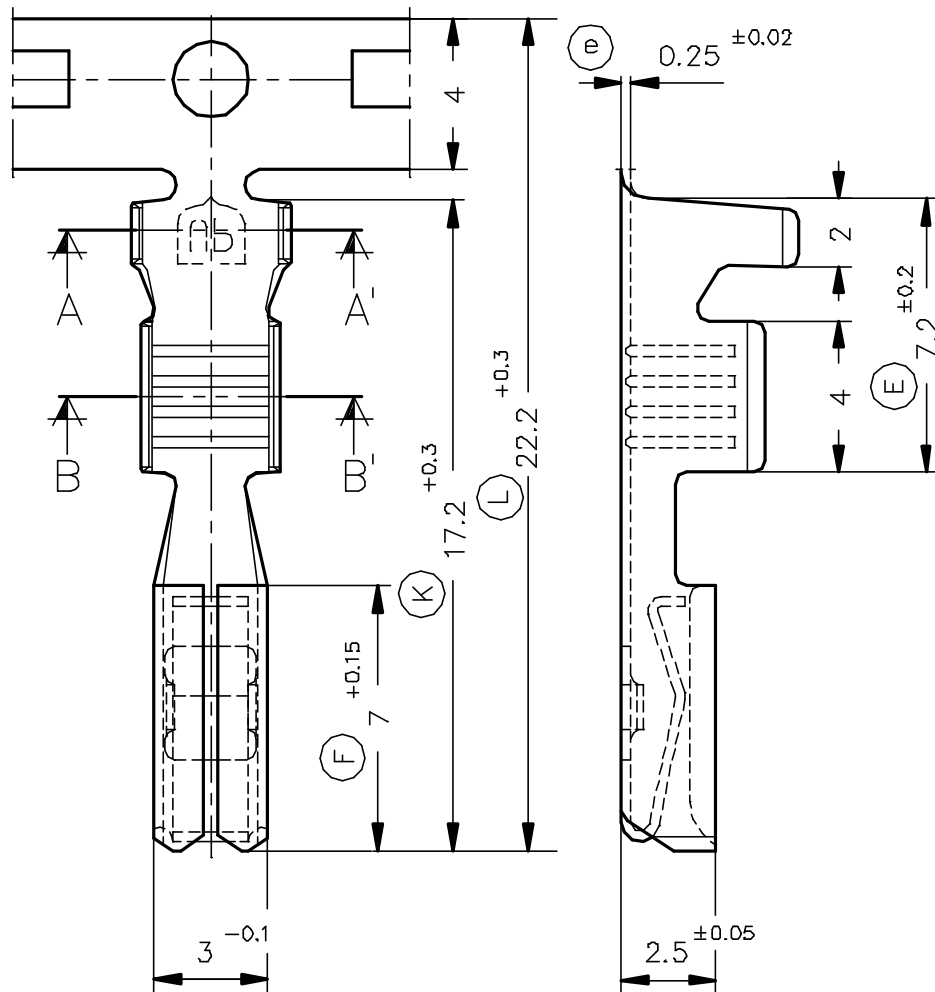
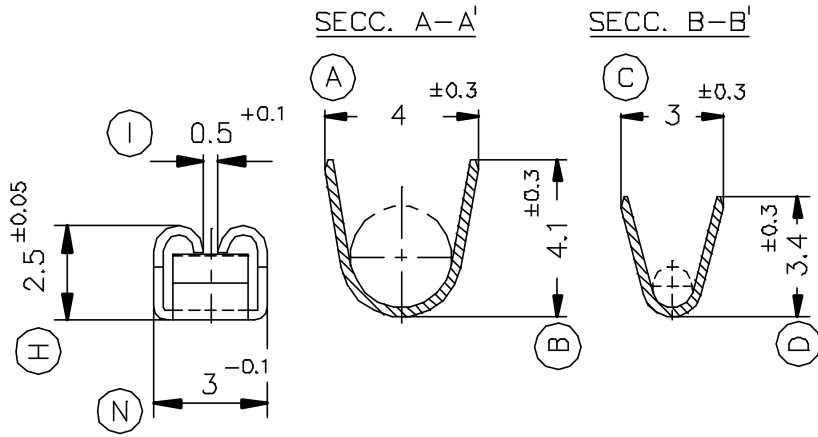

4458.31	Pre-Estañado	Bronce	1 ÷ 2 mm <sup>2</sup>	2.1 ÷ 2.7 mm.	2.3x0.65																
4458.30	Natural	CuSn6																			
4458.01	Pre-Estañado	Latón																			
4458.00	Natural	CuZn30																			
Referencias	Acabados	Material	Sección Conductor	φ Aislante	Para Macho	A	B	C	D	Rev.	Modificación	Fecha									



TERMINAL HEMBRA Serie 2.3



DIBUJADO	Gemma	12/09/94	NORMAS MATERIALES DIN17670	NORMAS DIMENSIONALES Especiales	TOLERANCIAS GENERALES ±0.2 ±2°	FORMATO	A4v
CONTROL	F.Adamuz	12/09/94				NOMBRE	PT4458 "c"
ESCALA	5/1		REF.		4458.xx		