

FORMA DE SUMINISTRO

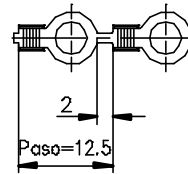

Esc. = 1:1

Secc. Z-Z'

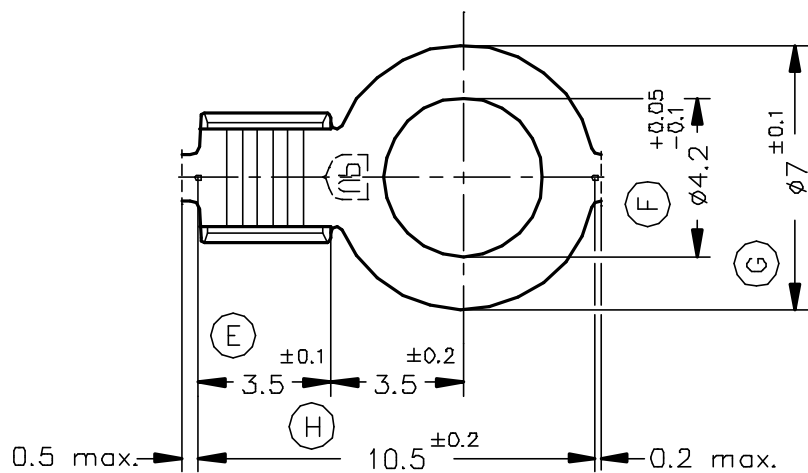
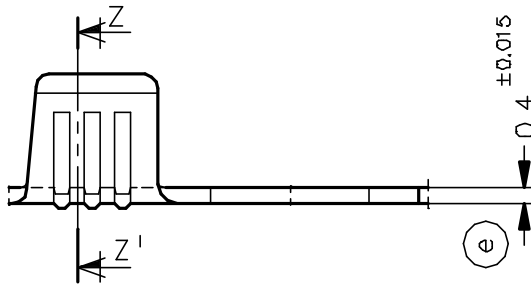
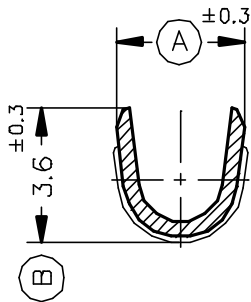

3626.32	Estañado	Bronce	0.5÷1.5mm <sup>2</sup>			3.4														
3626.30	Natural	CuSn6																		
3626.24	Pre-Niq.	Acero																		
3626.04	Niquelado	Latón CuZn30																		
3626.02	Estañado																			
3626.00	Natural																			
Referencias	Acabados	Material	Sección Conductor	φ Aislante	Para Macho	A	B	C	D	Rev.	Modificación	Fecha								



ESCUBEDO  
Españalites Eléctricas Escubedo S.A.

TERMINAL PARA TORNILLO φ7 A4-1.5

Terminales



Electricos

DIBUJADO	Gemma	10/10/94	NORMAS MATERIALES DIN17670	NORMAS DIMENSIONALES Especiales	TOLERANCIAS GENERALES ±0.2 ±2°	FORMATO	A4v
CONTROL	F.Adamuz	10/10/94				NOMBRE	PT3626 "c"
ESCALA	5/1		REF.		3626.xx		