

7544.** MINI UP-LOK · MALES FOR CONNECTOR



Specification	Males
Ø (mm)	1
Wire size mm² (AWG)	0,3-0,9 (22-18)
Ø Insulation (mm)	1,5-2,8
Counterpart	8540.** , 8542.** , 8544.**

Materials, temperature and contact resistance

Part nr.	Material	Finishing	Max. Temp. (°C)
7544.00	Brass	Natural	110
7544.01	Brass	Pre-tin-plated	120

Material thickness (mm) 0,2

Insertion / Withdrawal forces

	7544.00	7544.01
1st Insertion (max)	8N ¹	8N ¹
1st Withdrawal (min)	2N ¹	
1st Withdrawal (max)		2N ¹

¹ Valid for Mini - UP LOCK (female)

Application tool MN7544

Wire strip length 3.0 (±0.5) mm

Crimping parameters & pull out force

Wire section (±10%)	Conductor 		Insulator	Pull-out force (N)
	Height (mm)	Width (mm)	Width (mm)	
0.35 mm ²	0.90 (±0.03)	1.54 (±0.03)	2.68 (±0.10)	40N @ 60s
0.50 mm ²	1.00 (±0.03)	1.55 (±0.03)	2.73 (±0.10)	56N @ 60s
0.75 mm ²	1.10 (±0.05)	1.56 (±0.05)	2.78 (±0.10)	84N @ 60s
1.00 mm ²	1.20 (±0.05)	1.57 (±0.05)	2.78 (±0.10)	108N @ 60s

Values only valid for the application tool specified upwards. The insulator widths are only indicative as they are dependent on the sheath thickness of the wire used.

Winding number 5500

Compatible connectors 22031**, 22032**, 22033**, 22034**, 22036**, 22039**

Approvals



7544.**
MINI UP-LOK · MALES FOR CONNECTOR



Drawing

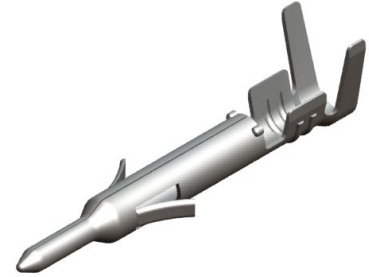
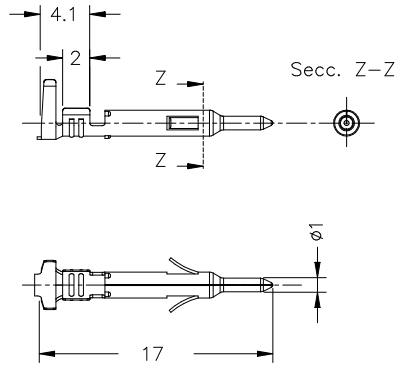

Disclaimer

Data obtained from Escubedo Laboratory essays, using own methodology, cablings, equipment and original crimping tools, done in laboratory conditions and following the indicated standards, errors and omissions excepted. This document has no contractual meaning and it is publiscised only for informative purposes. It can be changed without prior notice. The end customer has the sole responsibility to check these characteristics in its environment and with its own components, manufacturing methods and equipment. See also the full range product overview if available. For further information please visit our web site or contact us

Rev. Nr.	Concept	Date	Created/Revised	Approved
A2	Change company name and logo	2021-10-21	Laboratory Dept.	E. Roura
A1	Datasheet generated automatically [A1]	2019-09-03	Laboratory Dept.	E. Roura

Escubedo Connection Systems, S.A.U. · Ctra. de Girona-Olot Km. 35,5 · 17843 Riudellots de la Creu · Girona · Spain
Tel.: 34 972 171 706 · Fax: +34 972 171 714 · info@escubedo.com · www.escubedo.com