

4121E**

RAST 5 TERMINALS AND CONNECTORS · RECEPTACLES FOR CONNECTOR



Specification RAST 5 CRIMP CONNECT

For male (mm) 6,3x0,8

Wire size mm² (AWG) 0,5-1,5 (20-16)

Ø Insulation (mm) 2-3,3

Materials, temperature and contact resistance

Part nr.	Material	Finishing	Max. Temp. (°C)	Contact Resist (mΩ)
4121E00	Brass	Natural	110	0.65
4121E01	Brass	Pre-tin-plated	120	0.50
4121E02	Brass	Tin plated	120	0.55
4121E24	Steel	Nickel-plated	300	1.50
4121E30	Bronze	Natural	120	(T.B.D.)
4121E31	Bronze	Pre-tin-plated	130	(T.B.D.)
4121E32	Bronze	Tin plated	130	(T.B.D.)
4121E70	German Silver	Natural	210	2.00

Material thickness (mm) 0,4

Max. rated current

Wire section	4121E00 / 01 / 02 / 24 / 30 / 31 / 32 / 70
0.50 mm ²	8A
0.75 mm ²	10A
1.00 mm ²	12A
1.50 mm ²	16A

Insertion / Withdrawal forces

	4121E00 / 01 / 02 / 30 / 31 / 32	4121E24 / 70
1st Insertion (max)	20N ¹	25N ¹
1st Withdrawal (max)	40N ¹	40N ¹
6th Withdrawal (min)	13N ¹	13N ¹

¹ Valid for Natural Brass Tab

Application tool MN4120E

Wire strip length 5.5 (±0.5) mm

Crimping parameters & pull out force

Wire section (±10%)	Conductor 		Insulator	Pull-out force (N)
	Height (mm)	Width (mm)		
0.50 mm ²	1.40 (±0.03)	2.67 (±0.03)	3.68 (±0.10)	56N @ 60s
0.75 mm ²	1.50 (±0.05)	2.68 (±0.05)	3.69 (±0.10)	84N @ 60s
1.00 mm ²	1.60 (±0.05)	2.69 (±0.05)	3.70 (±0.10)	108N @ 60s
1.50 mm ²	1.70 (±0.05)	2.70 (±0.05)	3.70 (±0.10)	150N @ 60s

Values only valid for the application tool specified upwards. The insulator widths are only indicative as they are dependent on the sheath thickness of the wire used.

Winding number 8000

Compatible connectors P8412**, P8413**, P8414**, P8415**, R5315**-K, R5412**-K, R5413**-K, R5414**-K, R5415**-K, R5416**-K, R5417**-K

4121E**

RAST 5 TERMINALS AND CONNECTORS · RECEPTACLES FOR CONNECTOR



Approvals



Drawing

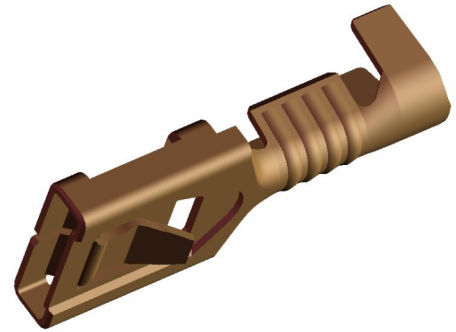
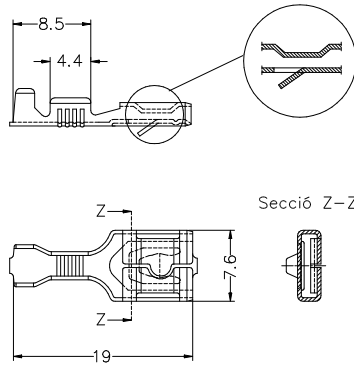

(T.B.D.): To be determined

Disclaimer

Data obtained from Escubedo Laboratory essays, using own methodology, cablings, equipment and original crimping tools, done in laboratory conditions and following the indicated standards, errors and omissions excepted. This document has no contractual meaning and it is publicised only for informative purposes. It can be changed without prior notice. The end customer has the sole responsibility to check these characteristics in its environment and with its own components, manufacturing methods and equipment. See also the full range product overview if available. For further information please visit our web site or contact us

Rev. Nr.	Concept	Date	Created/Revised	Approved
A3	Insertion and withdrawal forces - Update	2022-02-14	E. Roura (Laboratory Dept.)	O. Roura (Engineering Dept.)
A2	Change company name and logo	2021-10-21	Laboratory Dept.	E. Roura
A1	Datasheet generated automatically [A1]	2019-06-04	Laboratory Dept.	E. Roura

Escubedo Connection Systems, S.A.U. · Ctra. de Girona-Olot Km. 35,5 · 17843 Riudellots de la Creu · Girona · Spain
 Tel.: 34 972 171 706 · Fax: +34 972 171 714 · info@escubedo.com · www.escubedo.com